

D 10 Phone

Package contents | Lieferumfang | Contenu | Volumen de suministro |
 Leveringsomfang | Medföljande delar | Leveranseomfang

Setting up the base station | Basisstation aufbauen |
 Installer la station de base | Montar la estación base |
 Opbygning af basisstation | Ställ upp basstationen |
 Bygge opp basestasjonen



Getting started
 Advanced settings

Quick Guide Kort vejledning
 Kurzanleitung Snabbguide
 Guide rapide Hurtigstartvejledning
 Instrucciones resumidas

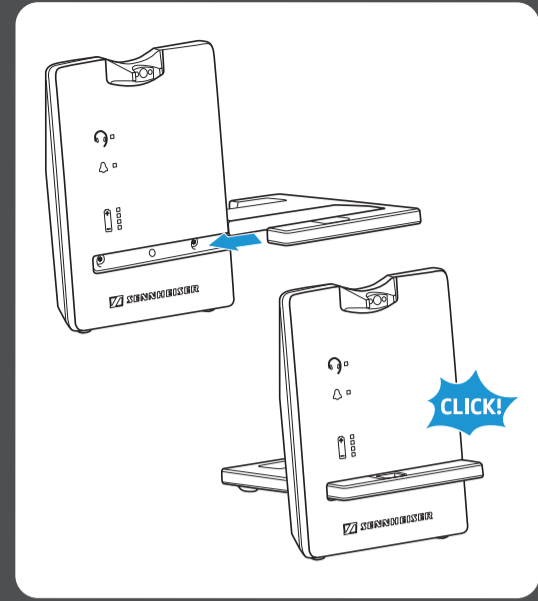
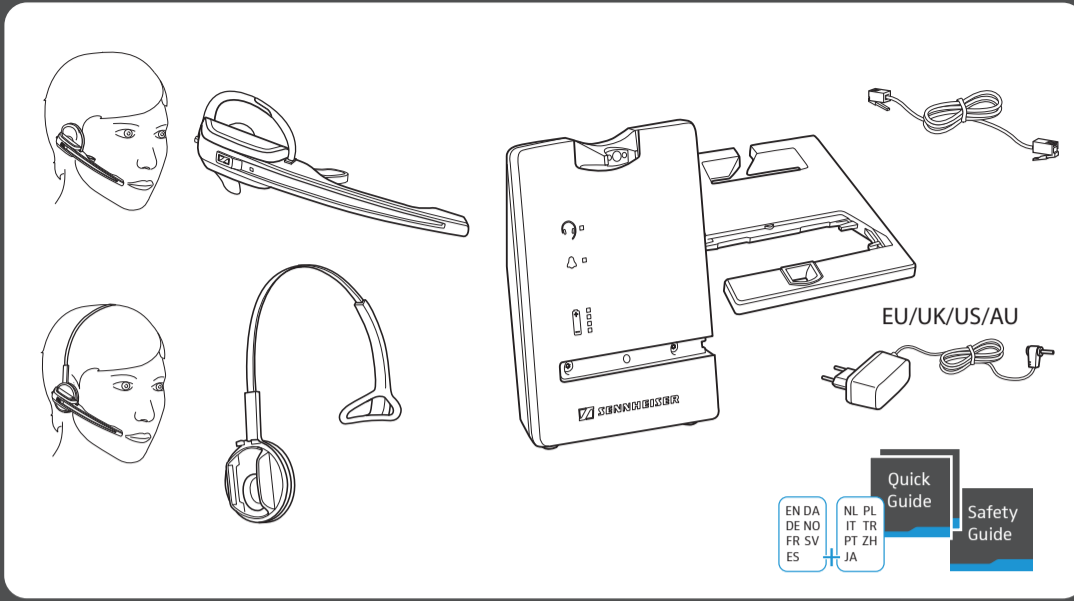

Specifications | Technische Daten | Caractéristiques techniques |
 Especificaciones técnicas | Tekniske data | Tekniska data

Connecting the base station to the mains power supply |
 Basisstation mit Stromnetz verbinden | Raccorder la station de base au secteur |
 Conectar la estación base con la red de corriente | Forbindelse af basisstationen med lysnettet |
 Anslut basstationen till elnätet | Koble basestasjonen til strømnettet

Charging the headset | Headset laden | Charger l'oreillette |
 Cargar el headset | Opladning af hovedsæt | Ladda headsetet | Lade hodesett

Connecting the base station to the fixed line telephone |
 Basisstation mit Festnetztelefon verbinden | Raccorder la station de base à un téléphone fixe |
 Conectar la estación base con el teléfono fijo | Forbindelse af basisstationen med fastnettelefon |
 Anslut basstationen till den fasta telefonen | Koble basestasjonen til fasttelefonen

For Instruction manual and software go to:

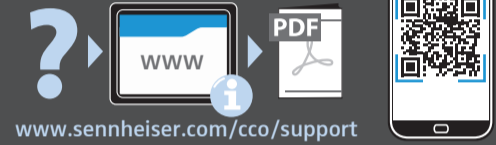

www.sennheiser.com/cco/support

Sennheiser Communications A/S
 Industriparken 27, DK-2750 Ballerup, Denmark
 www.sennheiser.com

Printed in China, Publ. 07/14, A01

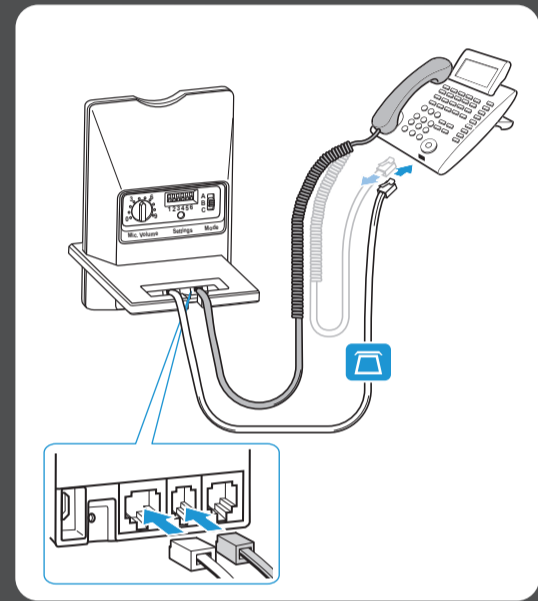
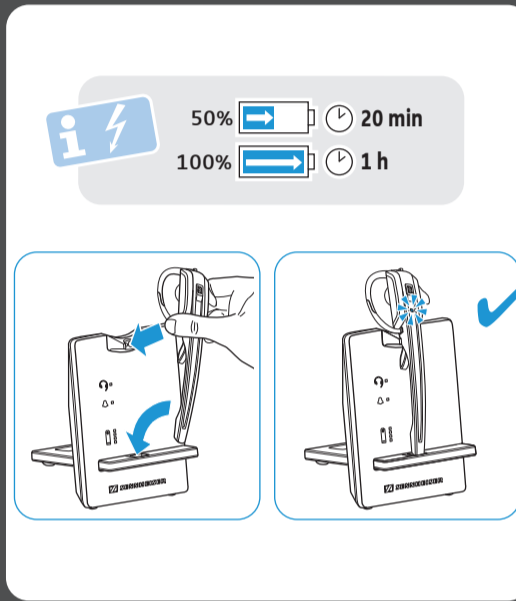
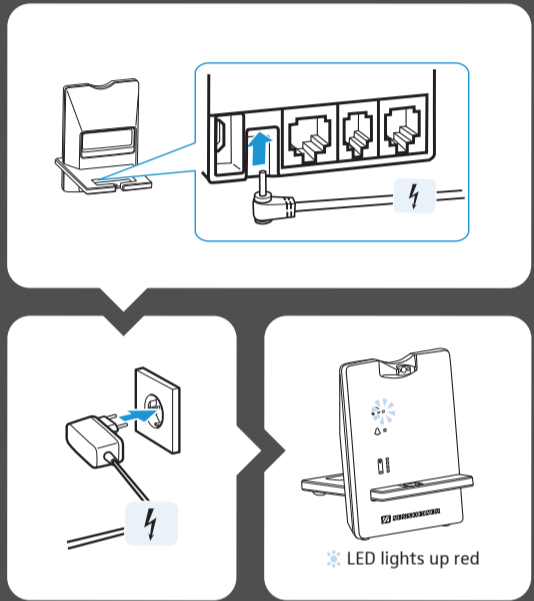

Using the headset | Headset verwenden | Utiliser l'oreillette | Utilizar el headset |
 Anvendelse af hovedsættet | Använd headsetet | Benytte hodesettet

Adjusting the dial tone of the telephone | Freizeichen für Telefon einstellen |
 Réglez la tonalité du téléphone | Ajustar la señal para marcar del teléfono |
 Indstilling af klartone til telefonen | Ställ in ledig linjesignal för telefonen |
 Stille inn telefonens summetone

Adjusting the microphone sensitivity for outgoing calls |
 Mikrofonempfindlichkeit für ausgehende Anrufe einstellen | Réglez la sensibilité du microphone pour les appels sortants |
 Ajustar la sensibilidad del micrófono para las llamadas salientes |
 Indstilling af mikrofonfølsomheden for udadgående opkald | Ställ in mikrofonens känslighet för utgående samtal |
 Stille inn mikrofonens ømfintlighet for utgående anrop

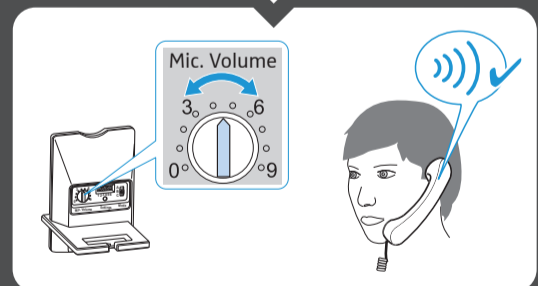
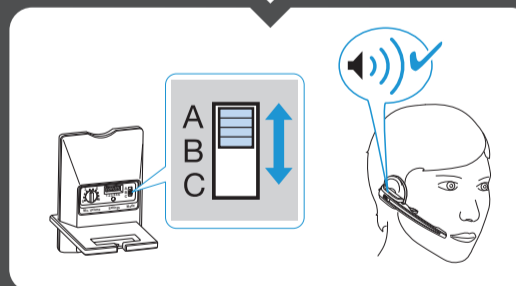
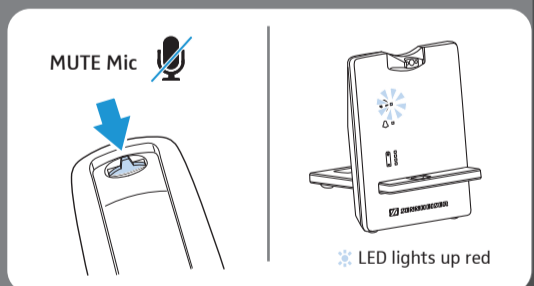
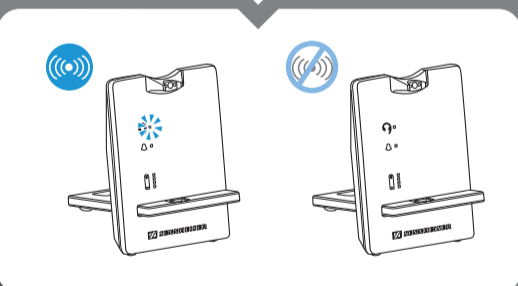
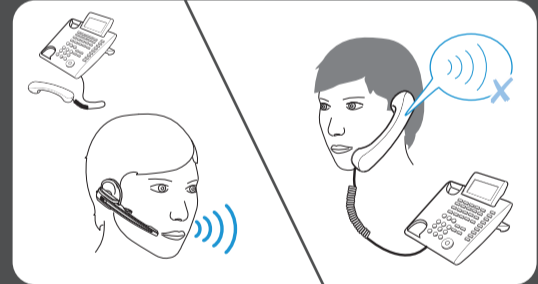
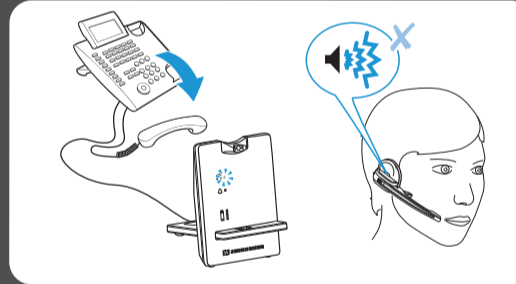
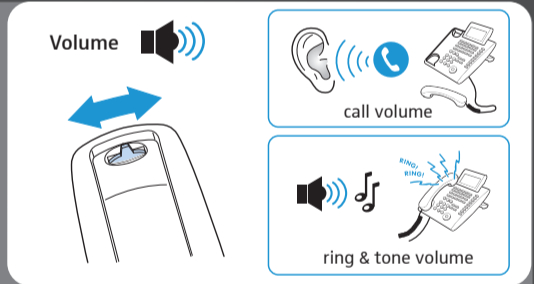
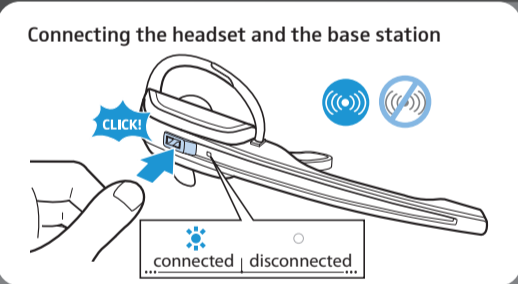

Wearing the headset with the earhook | Headset mit Ohrbügel verwenden |
 Porter l'oreillette avec le crochet d'oreille | Utilizar el headset con gancho de auricular |
 Anvendelse af hovedsættet med ørebøjle | Använd headset med öronbygel |
 Bruk hodesett med ørebøyle

Wearing the headset with the headband | Headset mit Kopfbügel aufsetzen |
 Porter l'oreillette avec l'arceau | Colocarse el headset con gancho de auricular |
 Sådan bæres hovedsættet med hovedbøjle | Sätt på headsetet med huvudbygel |
 Sett på hodesett med hodebøyle

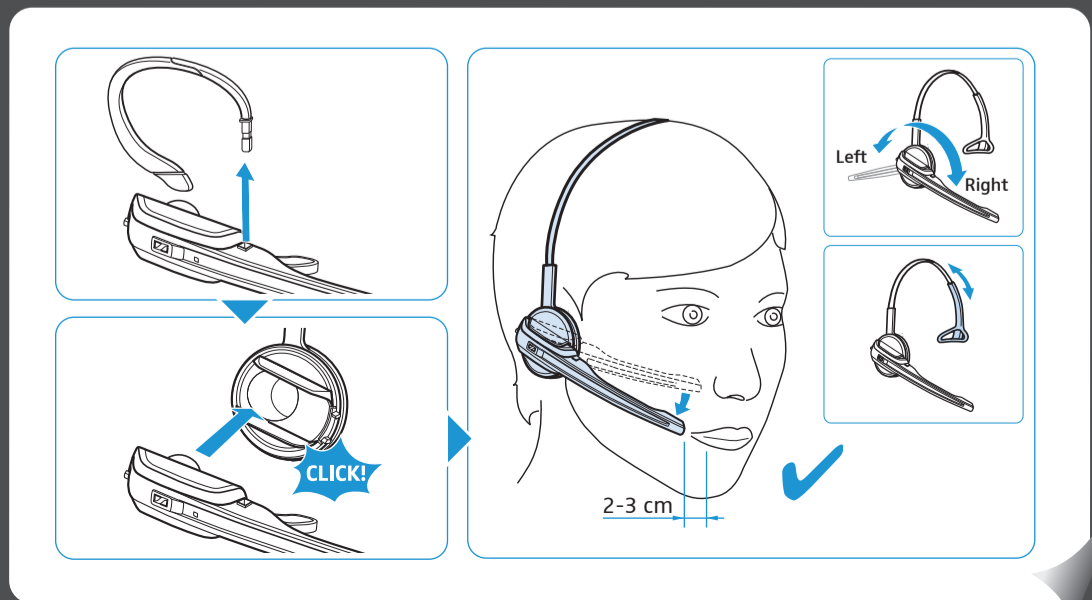
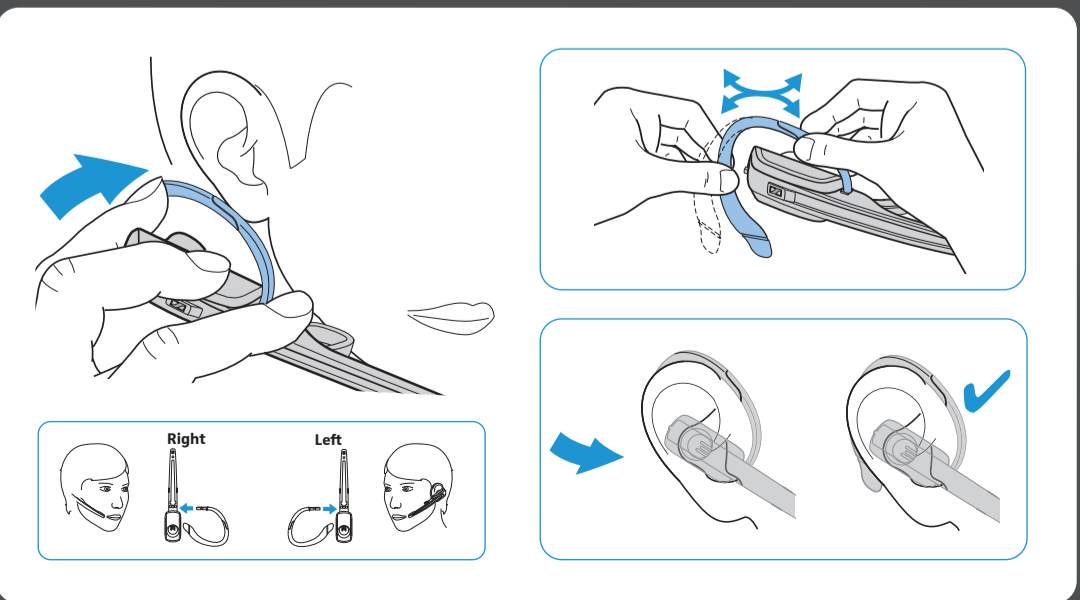

D 10 Phone



SENNHEISER

Swapping the assignment of the volume buttons | Belegung der Lautstärketasten tauschen | Permuter la fonction des touches Volume+ et Volume- | Cambiar la asignación de las teclas de volumen | Ændring af funktionen for lysterkeknappen | Ändra volymknapparnas funktion | Endre tilordning av lydstyrkeknappene

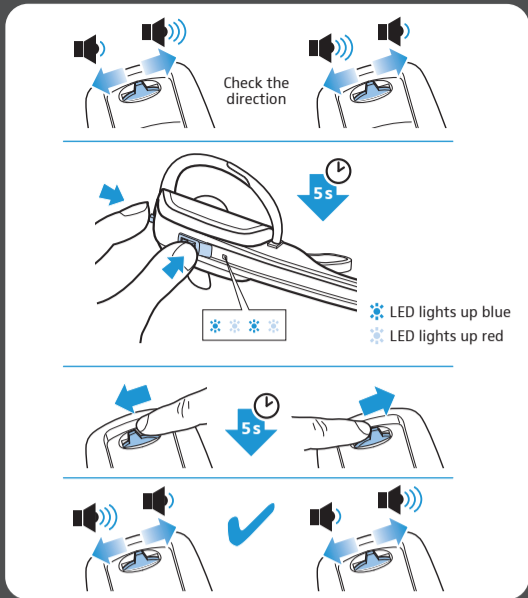

Making calls via the headset | Über das Headset telefonieren | Téléphonez avec l'oreillette | Telefonar mediante el headset | Opkald via hovedsættet | Ring med headsetet | Ringe ved hjælp av hodesettet

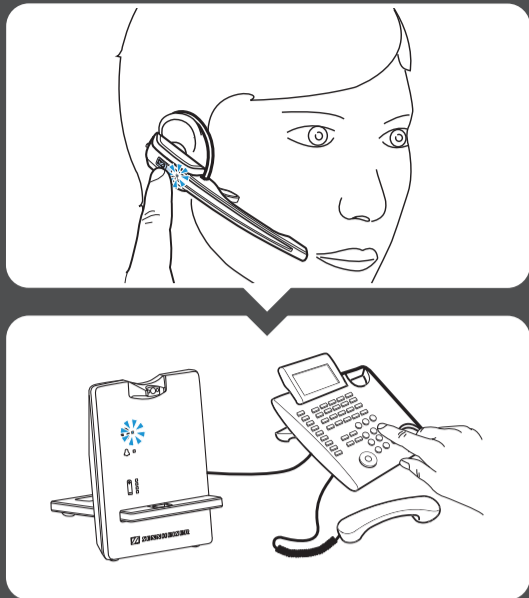

Automatic link establishment | Automatischer Verbindungsaufbau | Établissement automatique d'une liaison | Establecimiento de conexión automático | Automatisk forbindelsesopbygning | Automatisk oppkoppling | Automatisk forbindelsesopbygning

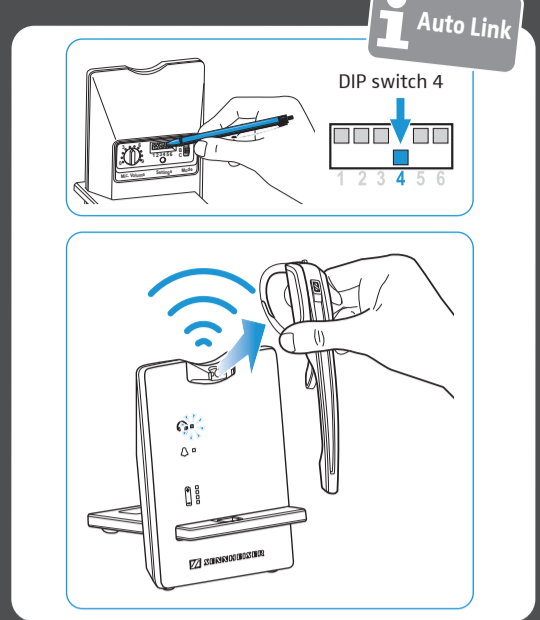

Adjusting the headset system using the DIP switches | Headset-System mit den DIP-Schaltern anpassen | Régler le système oreillette à l'aide des commutateurs DIP | Ajustar el sistema de headset a los interruptores DIP | Tilpasning af hovedsætsystemet med DIP-switches | Anpassa headsetsystemet med DIP-omkopplarna | Tilpasse hodesettssystemet med DIP-brytere

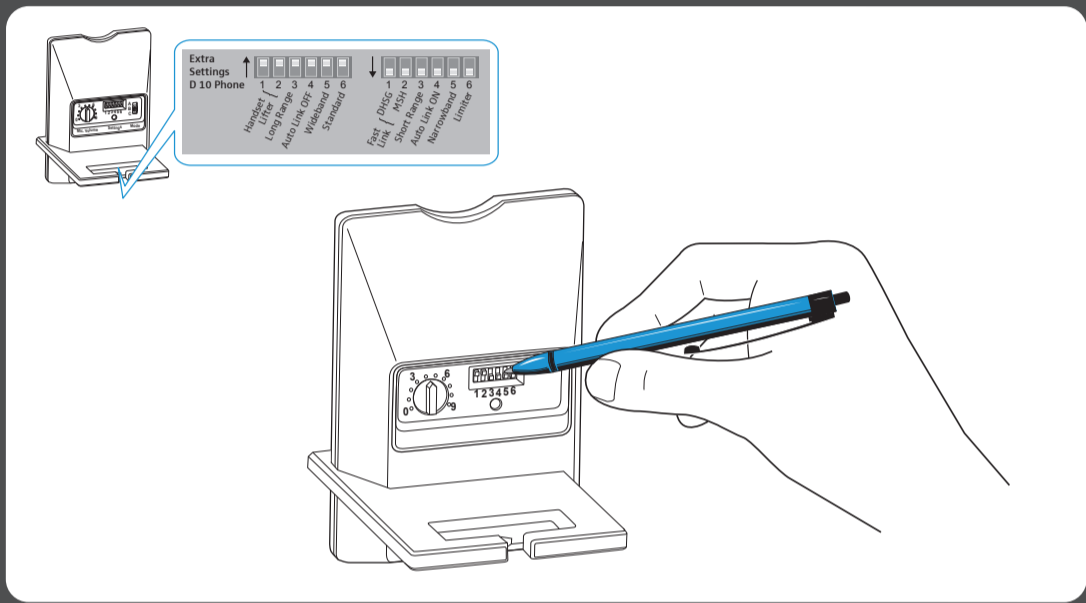

	Manual operation Lifts/hangs up the handset manually or using the handset lifter (Sennheiser HSL 10).		Manual link establishment When taking the headset out of the base station, you have to manually establish the wireless link between headset & base station.
	Electronic hook switch (DHSG standard) Call control via the headset system. For faster link establishment, see Fast Link.		Automatic link establishment – Auto Link When taking the headset out of the base station, a wireless link is automatically established between headset and base station.
	Electronic hook switch (MSH standard) Call control via the headset system.		Wideband audio transmission Automatic frequency adjustment of wideband & narrowband calls. Wideband audio transmission is e.g. supported by Skype & gives high speech quality. Battery life: 8 hours
	Fast Link for DHSG standard & HSL 10 handset lifter Recommended for frequent callers. Fast link establishment without delay due to hidden link to the base station.		Narrowband audio transmission Battery life: 12 hours
	Standard radio range		Standard limitation
	Reduced radio range Use this setting in order to avoid interference with other DECT systems. Range of approx. 10 m indoors		Limited volume (country specific) EU and US version: in compliance with Directive 2003/10/EC AU version: in compliance with Directive AS/ACIF G616:2006

Holding a conference call: Connecting the master headset & the guest headsets with a base station | Telefonkonferenz durchführen: Master-Headset & Guest-Headsets mit einer Basisstation verbinden | Tenir une conférence téléphonique : Connecter l'oreillette maître et l'oreillette invitée à la station de base | Realizar una conferencia telefónica: Conexión del headset maestro y de los headsets invitados con la estación base | Afvikling af en telefonkonference: Etablering af forbindelse mellem master-hovedsæt & gæst-hovedsæt og basisstationen | Telefonkonferens: Anslut masterheadsetet och gästheadseten till en basstation | Foreta telefonkonferanse: Opprette forbindelsen masterhodesettet og gjesthodesettet skal ha med basestasjonen

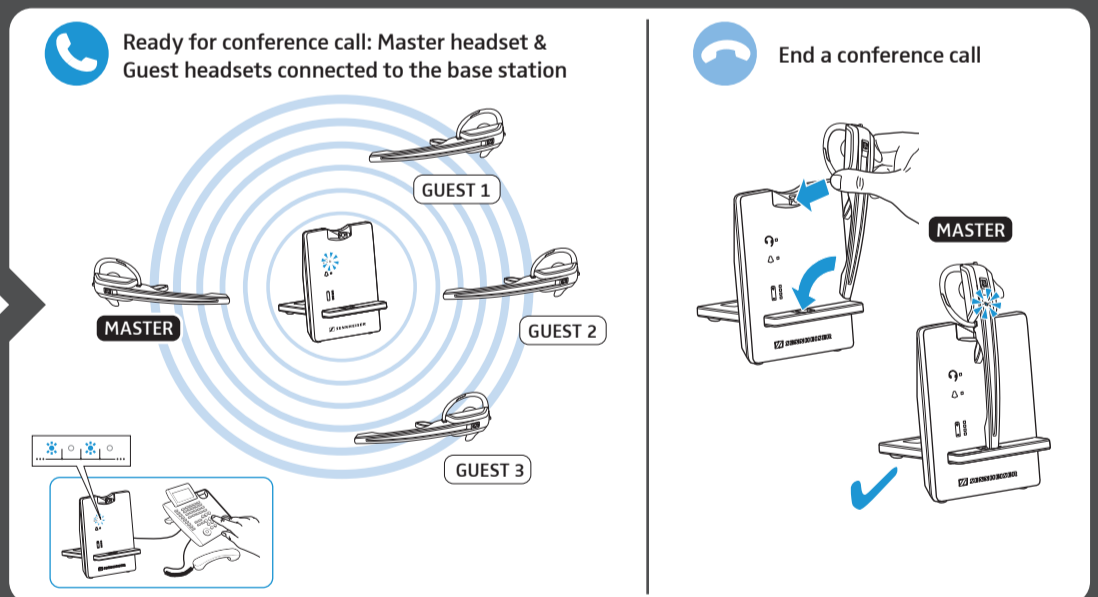
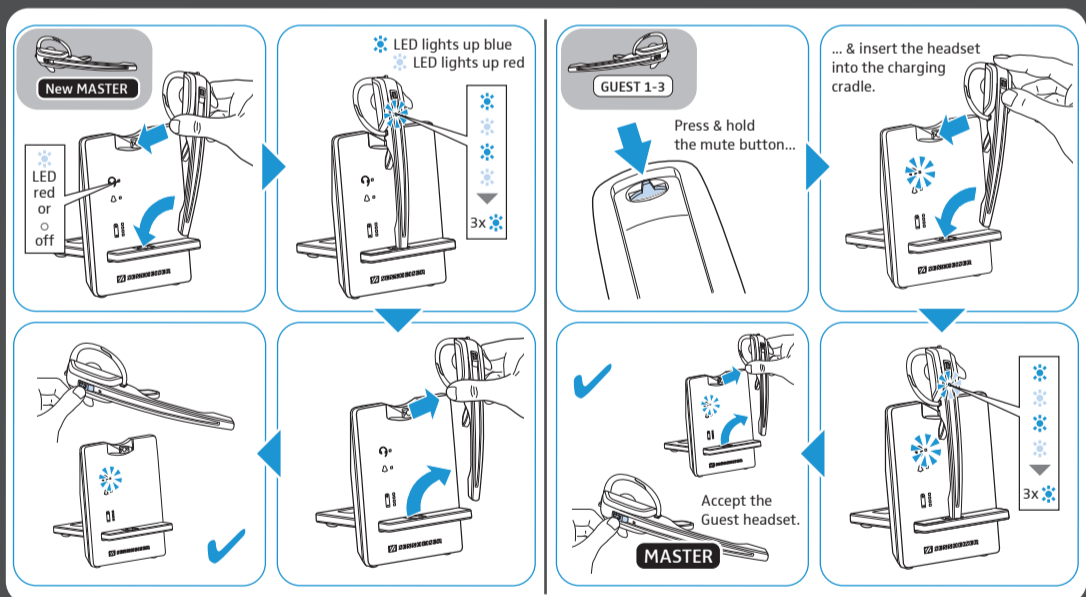

Leaving the DECT range | DECT-Reichweite verlassen | Sortir de la portée DECT | Salir del rango DECT | Sådan forlades DECT-rækkevidden | Lämna DECT-räckvidden | Forlate DECT-rekkevidden

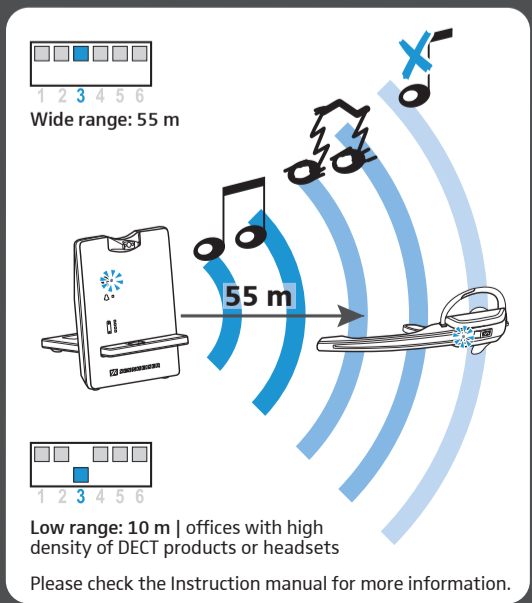

Replacing the ear pad | Ohrpolster austauschen | Remplacer le coussinet d'oreille | Cambiar las almohadillas para las orejas | Udskiiftning af ørepolstringer | Byta öronkuddar | Utskiiftning av øreputer

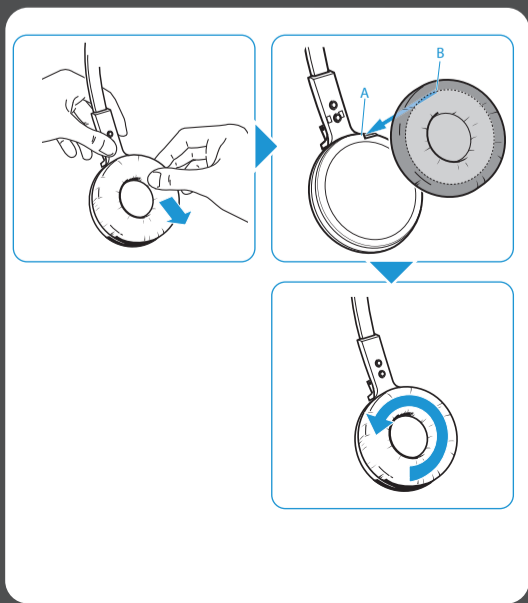

Charging several headsets simultaneously | Mehrere Headsets gleichzeitig laden | Charger plusieurs oreillettes simultanément | Cargar simultáneamente varios headsets | Opladning af flere hovedsæt samtidig | Ladda flera headset samtidigt | Lade flere hodesett samtidig

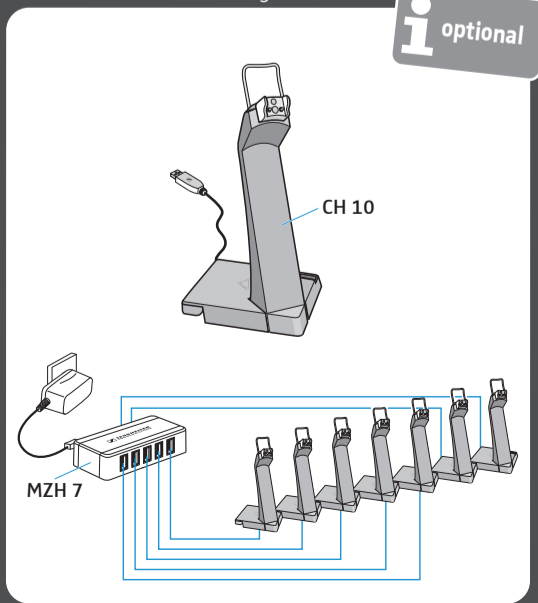

Detailed information / Accessories | Ausführliche Informationen / Erhältliches Zubehör | Informations détaillées / Accessoires | Información detallada / Accesorios disponibles | Udførlige oplysninger/tilbehør som kan erhverve | Mer informasjon/tilbehør | Detaljert informasjon / tilgjengelig tilbehør

